

# Storage, operating and maintenance instructions for AZ plug valves and Standard valves

Plug - Valves metallic with PTFE Sleeve 2 - 7 way

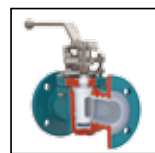

Plug - Valves FEP/PFA - lined, 2 - 3 way



Butterfly - Valves FEP/PFA - lined



Ball - Valves FEP/PFA - lined

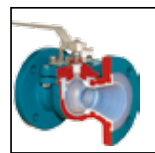

Ballcheck - Valves metallic with FEP/PFA - lined

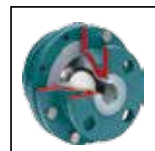

Sampling - Systems for liquid, liquid gas and gas



Special - Valves and customized

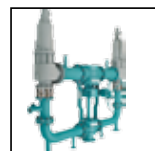

## **Content :**

1. General information
2. Marking
3. Safety instructions
4. Transport and storage
5. Installation and start-up
  - a) Mounting Instruction
  - b) Statement on Directives 2014/68/EU and 2006/42/EG
  - c) Installation in explosive areas (directive 2014/34EU, ATEX)
6. Handling and operating mode
7. Maintenance instructions
8. Trouble shooting of malfunctions and defects
9. Valve readjustment
10. Pressure tests

## 1. General information

These storage, operating and maintenance instructions apply for all AZ plug valves and other AZ products based on the plug valve design. AZ valves are high performance valves which can also be used under extreme conditions. Due to this, the valves should be handled carefully in order to avoid damages which could be hazardous to human health and/or the environment. Please consider the relevant remarks in this manual.

Please check the valves immediately after receipt for any defects or transport damages. Claims for transport damages can only be accepted if the forwarder is informed immediately in writing. For return shipments (transport damage or valve repair) please issue a damage report immediately and return the components back to the manufacturer, if possible in the original packaging. Returning shall be sent free of charge for AZ. Other returning terms have to be agreed with the AZ sales department.

Please provide the following information as a minimum for the returned valves:

- Name and address of the consignee
- Order number or AZ reference number
- Type of valve
- Description of the defect

The valve guarantee period must be agreed and confirmed by AZ at the order confirmation stage. If no agreement has been reached between the buyer and the seller, the standard guarantee period as per our general sales terms and conditions must be applied. In any case, the general warranty terms of AZ Armaturen GmbH always apply. We assume no liability if our storage, operating and maintenance instructions have been ignored and /or used for inappropriate installation or maintenance work. The end user is responsible for the materials selection regarding media consistency. AZ Armaturen can provide additional technical information such as material recommendations from steel suppliers and references. However, AZ Armaturen doesn't give any warranty regarding material adequacy and resistance.

## 2. Marking

According to EN 19 every valve is marked with the following data:

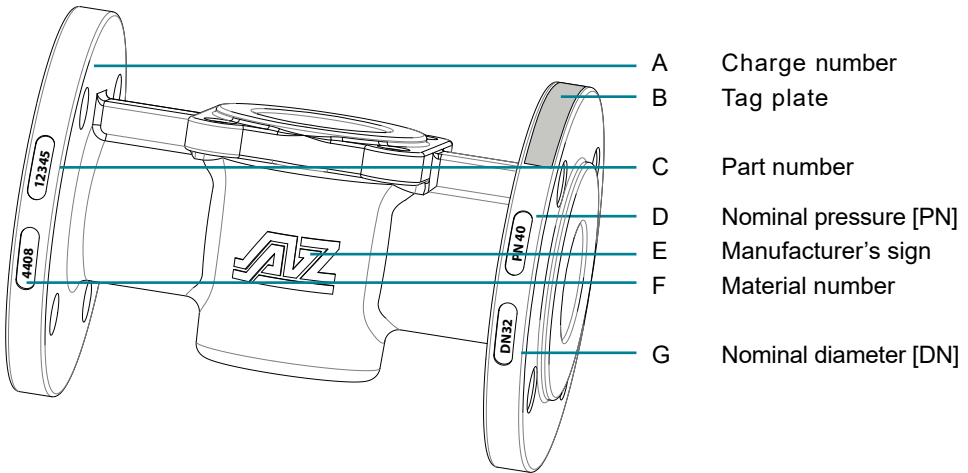

Valves which are covered by the pressure equipment directive 2014/68/EU (> DN 25 / 1") are additionally marked with a non-removable CE-identification tag plate. This tag plate also includes the test centre identification number, the fitting serial number along with its coded year of manufacture (the first two digits stand for the year of manufacture) and the permissible operating conditions ( $T_{\min}$ ,  $T_{\max}$ ,  $P_{\max}$ ):

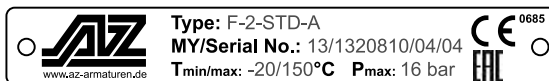

### 3. Safety instructions

AZ valves are high quality products manufactured according to the latest applicable technical regulations, and have left the manufacturer's workshop in perfect condition. Installation, adjustment, maintenance and repair work of valves, pneumatic accessories and electrical equipment shall only be executed by correctly trained and authorized personnel. AZ Armaturen GMBH accepts no liability for damage caused by unauthorized modification of any item and/or the use of non-genuine AZ spare parts.



**National legislation for accident prevention and/or the site specific advice of the end user must always be considered. This manual is in no way intended to replace these regulations.**

Before starting any repair or maintenance work, actuators and electrical parts have to be de-energized. Please consider a safe distance to open mounted and moving parts in order to avoid injury. Ensure that the valves are utilized only within the permitted limits (especially pressure and temperature). Information about these limits can be found in the technical information leaflet of the valves or on the valve tag plate. Operation of valves beyond the permitted temperature and pressure limits can cause damage to the valve, especially on gaskets and components.

Valves may only be used for the purpose that they have been designed for.



**IMPORTANT NOTE:**

**Never carry out any maintenance or repair work if the valve is under pressure. Please consider that some valves can trap pressurized medium (e.g. in the plug of the plug valve).**

**IMPORTANT NOTE:**

**The piping system where the valve is installed has to be pressure-free and any media over pressure has to be released before dismantling. Check potential risks which can be caused by media residues. Please consider that media can be released from the valve or piping during dismantling.**

In case of toxic / dangerous / harmful media, the pipe has to be emptied completely before dismantling the valve. Hot valves must be cooled down to ambient temperature before work starts.

For your own safety, please always use the correct protective clothing or special equipment which is required for work with a particular media.



## **4. Transport and storage**

AZ valves must be stored in fully open position. In certain cases (actuated valves with fail safe position “closed”), the valves can be stored in closed position, but storage in a half open position has to be avoided at all times. AZ valves are delivered with the end connections covered by protection caps. These caps protect

the valve ends from mechanical damage and the internals from environmental influences (e. g. dust, dirt etc.). The protective caps shall only be removed when the valve is to be installed. The valves shall be stored indoors in order to protect them from destructive influences like dirt, moisture and frost. The valves shall be transported in solid and stable packaging to the place of installation. Lifting accessories (ropes, belts) shall only be attached to the valve bodies. Never use the levers, gear boxes or actuators to lift the valves.



**IMPORTANT NOTE: Valves which have been installed in toxic or aggressive media applications must be flushed and cleaned before returning them to the supplier for repair or disposal. Media may be located underneath the plug so the valve must be disassembled, the plug removed and all individual parts must be provided fully cleaned. A certificate of non-objection and a material safety data sheet must be attached to the shipping documents and shall be included in the delivery.**

## 5. Mounting Instruction and start-up

### a) Mounting Instruction

Important Note: This does not apply for check valves, control valves and sight glasses. These valves are marked with an arrow indicating the flow direction. Valves which are equipped with a plug with relief hole or a "T4"-plug, a notch on the plug stem indicates the orientation of the overpressure relief side.

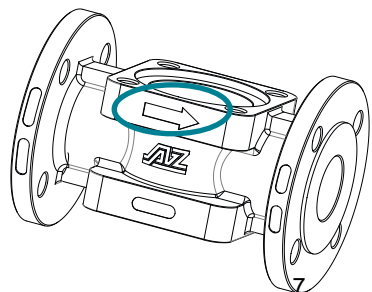

Obey Flow direction  
(Sight glasses a.s.o.)

In order to avoid valve damage caused by line impurities (swarf-, dirt, welding residues) the pipeline must be emptied and cleaned before installation of the valves. Prior to installation, ensure that the valve is in open position and the valve end protection caps are removed. Check the sealing surface of flanged valves for damage. In case the valve has been stored without protection caps, please make sure that the valve is clean inside. If necessary flush the valve with clean and dry air.

The valves must be installed stress-free in the pipeline. For example, stress can occur due to misaligned pipelines. Place the valve in the piping, if needed, by using lifting accessories. Flanges shall be bolted constantly crosswise. Please consider the stipulated fastening torque of the gasket manufacturer. Flanges and bolting should be clean. A flange gasket which is suitable for the application shall be used. Please ensure that the valves are properly supported during installation. Normally the valves can be installed in any position. However, please consider a support / bearing for heavy actuators if the valve is mounted in a vertical pipe or the actuator orientation is not on top of the valve / piping (sideways).



**In order to protect the valve's internal sealing from overheating, please make sure that there is sufficient cooling if the valve is welded into the pipeline (butt weld / socket weld end valves).**

Please check the whole valve for proper operation by repeated opening and closing before commissioning (<2 strokes per minute). In case of prolonged storage of the valve the breakaway torque during the first stroke may be higher than usual, after frequent operation the torque will reduce to the normal level.

Please check if the hand lever or the actuator is installed in such a manner that the valve closes clockwise. When installing multi way valves (three-way, four-way etc.) please check the port form and the switching positions in order to avoid incorrect connection to the piping. The switching positions are shown on the position



indicator (hand operated valves) or by red marks on the coupling (actuated valves). Please finish all installation work before putting the valves into operation. RECOMMENDATION: If the operating temperature exceeds 120°C the plug may be adjusted once operating temperature has been reached (1/2 to 1/1 turn of the adjustment bolt).

### **b) Statement on Directives 2014/68/EU and 2006/42/EG**

AZ valves are pressurised equipment components according to the Pressure Equipment Directive 2014/68/EU. The design, manufacture, and testing of the valves comply with the requirements of this directive. On the basis of its prescribed use with its installed pneumatic, electric, or hydraulic drive, AZ-Armaturen are classified as “incomplete machinery” within the meaning of Machinery Directive 2006/42/EG. On the basis of their intended use, AZ valves, with installed pneumatic, electric or hydraulic drives, are considered “incomplete machinery” according to the Machinery Directive 2006/42/EG. The valves must be used exclusively in the same way that their specifications are described in this operating manual. The automated valve may only be commissioned after the pipeline has fully been installed.

### **c) Installation in explosive areas (directive 2014/34/EU (ATEX))**

AZ valves has undergone a hazard analysis according to directive 2014/34/EU (ATEX). Result:

- According to DIN EN 13463-1:2000 AZ-valves don't have an own potential ignition source and therefore they are not covered by the scope of application of code 2014/34/EU (ATEX).
- There's no marking according to ATEX.
- All valves can be used in explosive areas ( zone 0,1,2 and 20,21,22).

**IMPORTANT NOTE:**

- Fully lined valves which are installed in zone 0 and 20 have to be lined with conductive PFA material. A static eliminator device has to be assembled in order to connect the plug with the body (grounding).
- AZ valves can be operated manually (e.g. hand lever, gear box) as well as mechanical or electrical (e.g. pneumatic, hydraulic or electric actuator).
- For electrical and mechanical actuators and accessories an own declaration of conformity according to code 2014/34/EU may have to be considered.
- Whenever fully lined valves with non-conductive lining are installed in explosive areas, AZ-Armaturen GmbH strongly recommends the use of an anti-static band/earth cable in order to ensure grounding of the plug.

## **6. Operation and functionality**

**Ball and plug valves** are installed in pipeline systems by flanging, screwing or welding and are designed to conduct, block or control media flow. On/off valves have the open and closed position indicated by the lever position (lever longitudinal to the valve = open, lever perpendicular to the valve = closed) or by a position indicator on top of the gear box. Flow directions of multiport valves are indicated by a notch on the plug stem or by a position indicator assembled on top of the plug or the gear box. Flow directions of actuated valves are indicated by red markings on the coupling between valve and actuator.

**Jacketed valves** are used for particular media in order to maintain the process capability or the flow.

**Control valves** are used for the adjustment and the relocation of a certain process factor (mass flow, pressure, temperature).

With **sampling valves** and sample systems representative samples are taken during the ongoing process out of chemical, petrochemical and pharmaceutical systems in order to monitor and control the media quality.

A **sight glass** with optical transparent glass can be used for observing process flow. A strainer protects dirt sensitive installations as measurement devices or pumps from line impurities

## 7. Maintenance instructions

Under normal conditions and in the case of the use according to the regulations, frequent maintenance work on AZ valves is not necessary. After an extended period of operation, AZ recommends checking the function of the valve by repeated open-close strokes. Tightness of the valve/pipe connection and valve cover area may also be visually checked for leakage. The functionality of valves which remain constantly in the same position should be checked frequently, e. g. by performing a "partial-stroke-test".

After a certain operating time, leakage can occur due to wearing of the sealing parts, small leakages (depending on type of sealing) can be stopped by tightness adjustment (please refer to pages 7 + 8).

After finishing maintenance or repair work please check the proper function of the valve (particularly the closing position of actuated valves) and the tightness of the connection between valve and piping.

## 8. Malfunction / defects and fault clearance

Malfunction	Possible reason	Fault clearance
Leakage in the passageway	<ul style="list-style-type: none"> <li>• The allowed valve operating limits (pressure / temperature) have been exceeded.</li> <li>• Damage of the sleeve or plug resp. ball surface caused by foreign particles.</li> <li>• Wearing of the sleeve.</li> <li>• Damage of the valve due to chemical corrosion, caused by wrong material selection regarding media suitability.</li> </ul>	<ul style="list-style-type: none"> <li>• Check if the valve closes completely.</li> <li>• Adjustment of the plug according to the guideline (please refer to pages 13 + 14).</li> <li>• If the leakage cannot be stopped the valve has to be repaired.</li> </ul>
External leakage (cover or stem seal)	<ul style="list-style-type: none"> <li>• The allowed valve operating limits (pressure / temperature) have been exceeded.</li> <li>• Wearing of the sleeve.</li> <li>• Damage of the valve due to chemical corrosion, caused by wrong material selection regarding media suitability.</li> <li>• Cover bolting became loose (e.g. caused by heavy vibrations in the pipeline)</li> <li>• Wearing resp. damage of the cover seal.</li> </ul>	<ul style="list-style-type: none"> <li>• Adjustment of the plug according to the guideline (please refer to pages 13 + 14).</li> <li>• Check if the cover bolting is fastened properly.</li> <li>• If the leakage cannot be stopped the valve has to be repaired.</li> </ul>
High torque/ valve blocks	<ul style="list-style-type: none"> <li>• Possible change of the media aggregate state.</li> <li>• Deposit of media on plug resp. ball surface.</li> <li>• Solid media or forgotten installation devices in the valve</li> </ul>	<ul style="list-style-type: none"> <li>• Remove deposits and solid media.</li> </ul>
Malfunction of actuator or accessories		See corresponding guidelines / manuals of the manufacturer.

## 9. Adjusting instructions

### Adjusting instructions in case of leakage for AZ plug valves type: ISO-STANDARD DN15-100 NPS 1/2"-4" / ISO-EXTRA DN15-80 NPS 1/2"-3"

1. Plug should be in an open position
2. Both adjusting bolts shall be turned 1/4 to 1/2 rotations clockwise one after another.
3. Afterwards move the plug 10-15 degrees and back.
4. If the valve is still leaking please repeat step 2) and 3).

Please do not over tighten the adjustment bolts as the breakaway torque may increase beyond the normal limits.

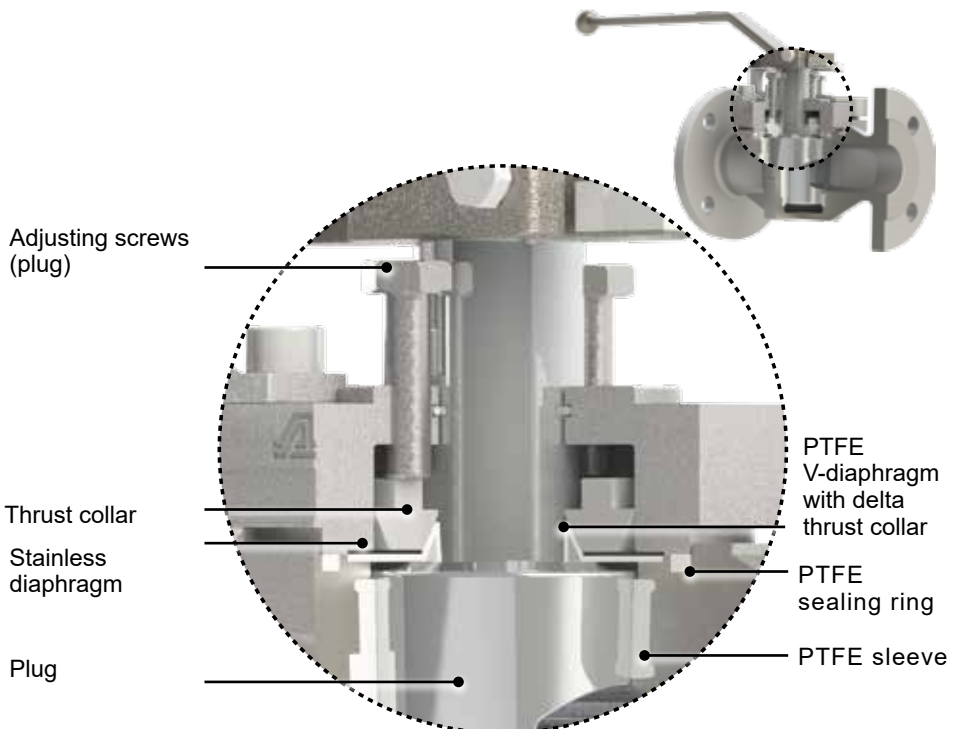

**Adjusting instructions in case of leakage for AZ plug valves type:  
STANDARD DN125-600 NPS 5"-24" / EXTRA DN100-600 NPS 4"-24"**

1. Plug should be in an open position
2. All adjusting bolts shall be turned  $\frac{1}{2}$  to  $1/1$  rotations clockwise one after another.
3. Move the plug 10-15 degrees and back.
4. If the valve is still leaking please repeat step 2) and 3).

NOTE: Please do not over tighten the adjustment bolts as the breakaway torque may increase beyond the normal limits.

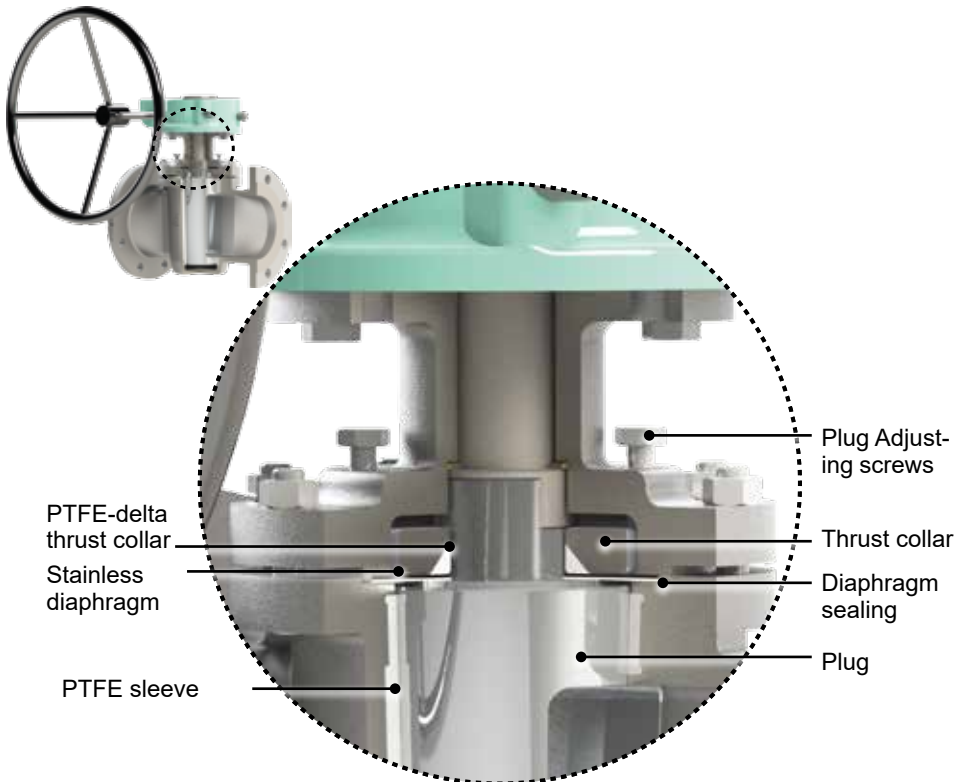

NOTE: Special cover sealing designs (e. g. type "FS-N") may vary.

## 10. Pressure tests

In accordance with ISO 5208 / EN 12266 and API 6D / API 598 hydrostatic strength tests using 1.5 times the nominal pressure (housing) are carried out at the factory. The complete valves are either tested hydrostatically using the indicated valve nominal pressure or an air tightness test using 6 bar is carried out.

For system specific pressure tests carried out by the operator the nominal pressure must not exceed 1.1 times of the value specified on the type plate (also refer to section 2 “Marking”). For test pressures higher than “1.1 x PN” there is the risk of damage to the PTFE (polytetrafluorethylene) seal. Higher pressure tests only after authorisation by AZ.

Pressure rating	Strength test (housing) with water		Tightness test, complete valve *)		AZ valves test pressure**)
	Standard	PN x 1,5 [bar]	Water [bar]	Air [bar]	PN x 1,1 [max. bar]
PN 10	ISO 5208 EN 12266	15	11	6	11
PN 16		24	17,6	6	17,6
PN 25		37,5	27,5	6	27,5
PN 40		60	44	6	44
PN 64		96	70,4	6	70,4
PN 100		150	110	6	110
PN 160		240	176	6	176
ANSI 150	API 6D / API 598	30	22	6	22
ANSI 300		75	55	6	55
ANSI 400		99	72,6	6	72,6
ANSI 600		150	110	6	110
ANSI 900		225	165	6	165

\*) Tightness test of the valve at closure

\*\*\*) Tightness test of the outward valve



AZ-Armaturen GmbH  
Waldstraße 7  
D-78087 Mönchweiler  
Telefon: +49 (0) 7721 7504-0  
Telefax: +49 (0) 7721 7504-13  
info@az-armaturen.de  
www.az-armaturen.de